

Electronics Merit Badge

Class 3

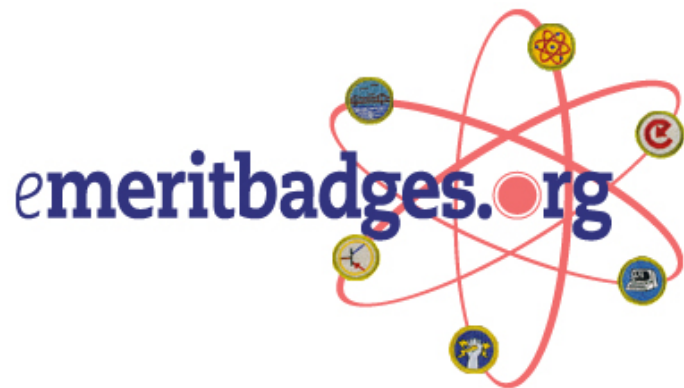

Name _____



Electronics Merit Badge

Class 1	AC Power Sources DC Power Sources Voltage, Current and Resistance Build Circuit with Light, Buzzer and Switch
Class 2	Components - Passive and Active Ohms Law Ohms Law Tool Kit Transistor Logic IC Logic
Class 3	Binary Logic Binary / Hex Tool Kit LED Circuit Design
Class 4	Solder Theory Solder Practice Build LED Kit

Binary Number System

There are various types of number coding systems.

Decimal is based on 10 different symbols: 0-9. This is useful for humans but too complex for computers.

A simpler system was developed for computers based on two symbols: “1” and “0”.

“0” usually represents ground (or 0 volts)

“1” usually represents a positive voltage (like +5 volts.)

This is called the Binary System. The computer uses a series of 1's and 0's that are grouped together in what is called a byte consisting of eight 1's and 0's. “10100101”

Each binary position has a numeric value that doubles with each increased position.

Binary Number System

Binary is a series of 1s and 0s. Each 1 or 0 is called a bit. A computer uses a series 8 bits that is called a byte. Each bit within the byte has a numeric value which is based on the power of 2, such that each number is 2 times higher than the next as noted below:

<u>Decimal</u>	<u>Binary Byte</u>		<u>8</u>	<u>4</u>	<u>2</u>	<u>1</u>	
	128 64 32 16 8 4 2 1						
0	0 0 0 0 0 0 0 0						
1	0 0 0 0 0 0 0 1	=				1	= 1
2	0 0 1 0 0 0 0 0	=			2	+ 0	= 2
3	0 0 1 1 0 0 0 0	=			2	+ 1	= 3
4	0 1 0 0 0 0 0 0	=	___	+ ___	+ ___	+ ___	= ___
5	0 1 0 1 0 0 0 0	=	___	+ 4	+ 0	+ 1	= 5
6	0 1 1 0 0 0 0 0	=	___	+ ___	+ ___	+ ___	= ___
7	0 1 1 1 0 0 0 0	=	___	+ 4	+ 2	+ 1	= 7
8	1 0 0 0 0 0 0 0	=	8	+ 0	+ 0	+ 0	= 8
9	1 0 0 1 0 0 0 0	=	___	+ ___	+ ___	+ ___	= ___

Binary/HEX Numbering System

<u>Decimal</u>	<u>Binary</u>								16	8	4	2	1	HEX	
	128	64	32	16	8	4	2	1							
0	0	0	0	0	0	0	0	0	=					=	00
1									=					1 = 1	= 01
2									=					2 + 0 = 2	= 02
3									=					2 + 1 = 3	= 03
4									=						=
5									=					4 + 0 + 1 = 5	= 05
6									=					4 + 2 + 0 = 6	= 06
7									=					4 + 2 + 1 = 7	= 07
8									=						=
9									=					8 + 0 + 0 + 1 = 9	= 09
10									=					8 + 0 + 2 + 0 = 10	= 0A
11									=						=
12									=					8 + 4 + 0 + 0 = 12	= 0C
13									=					8 + 4 + 0 + 1 = 13	= 0D
14									=						=
15									=					8 + 4 + 2 + 1 = 15	= 0F
16									=					16 + 0 + 0 + 0 + 0 = 16	= 10
17									=					16 + 0 + 0 + 0 + 1 = 17	= 11

Integrated Circuit Using Binary Language

Each time you press the button the output changes. 0 to 1 then 1 to 0. The output changes on each 0 to 1 transition. That is why it's called a Flip Flop. A Flip Flop takes two clock for one output change. That make is a divide by 2 function.

Binary Flip Flop

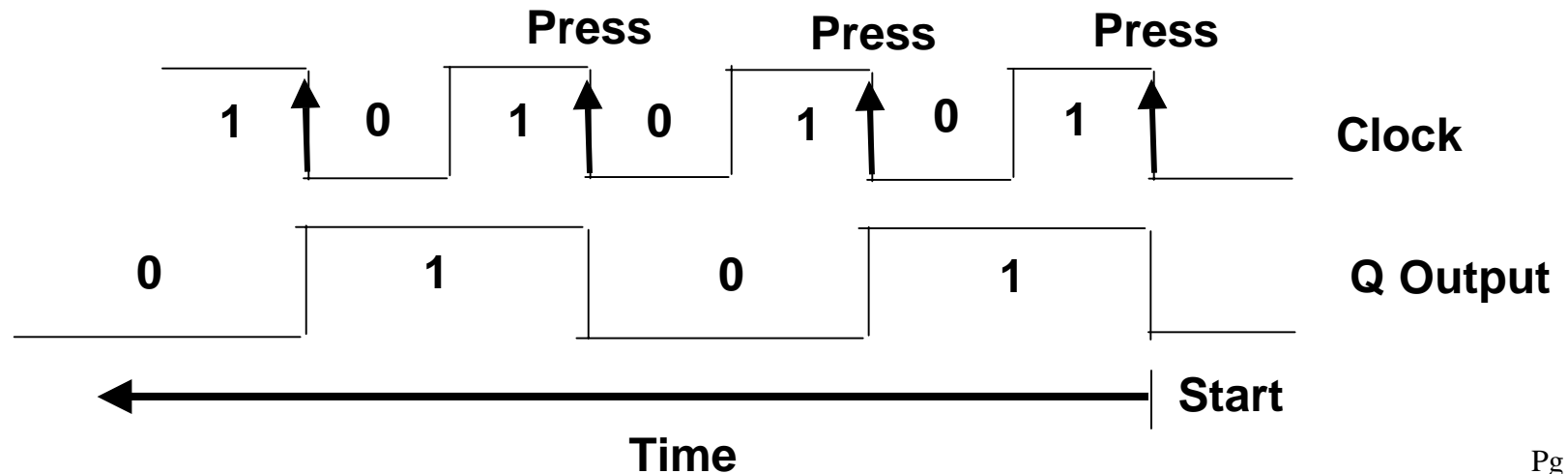
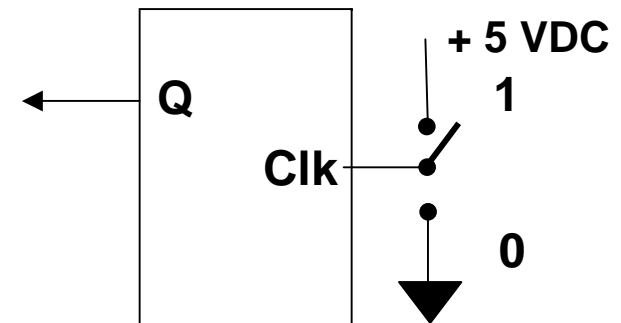

3m
14m

Integrated Circuit Using Binary Language

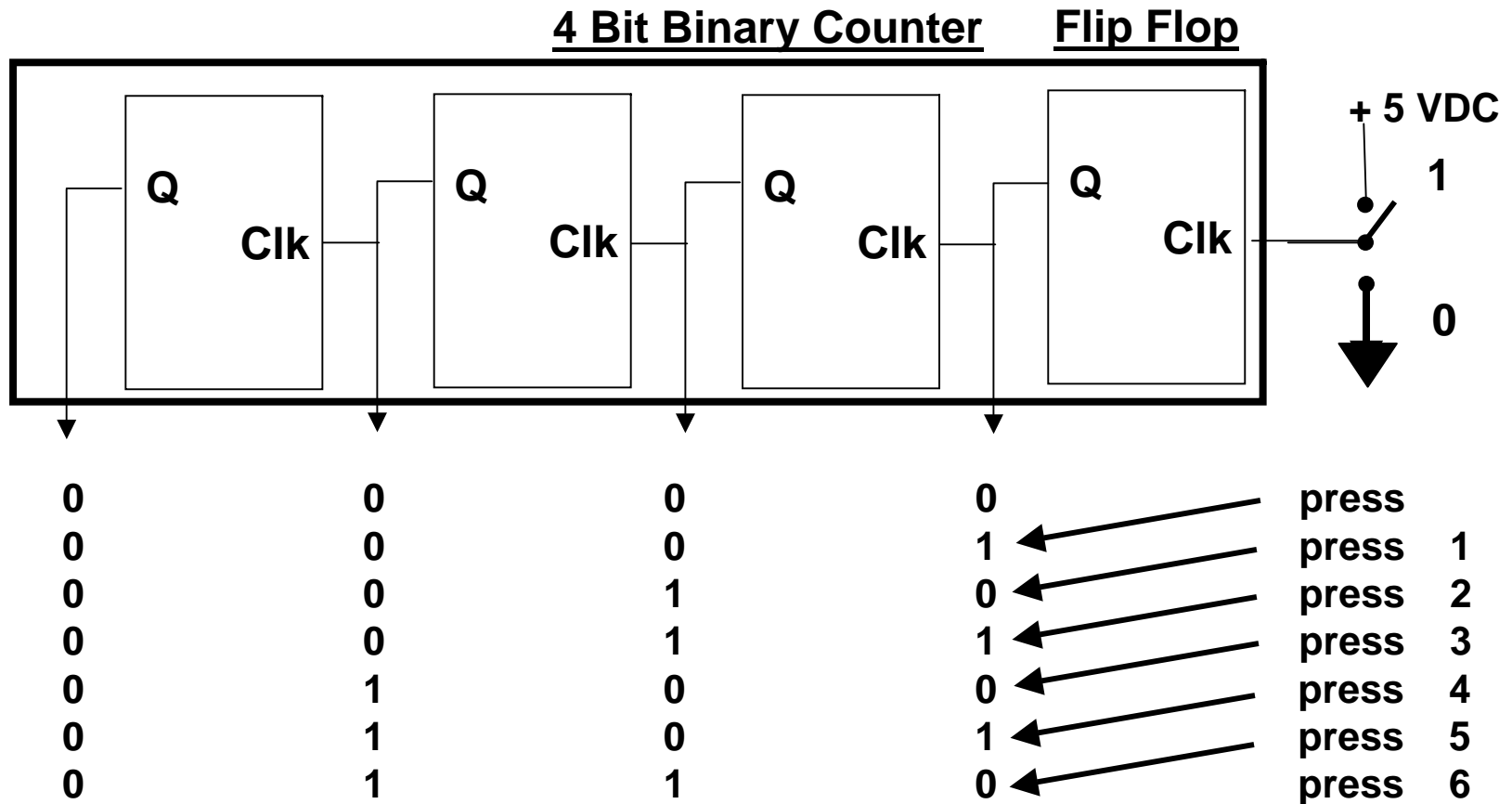

Binary Tool Kit

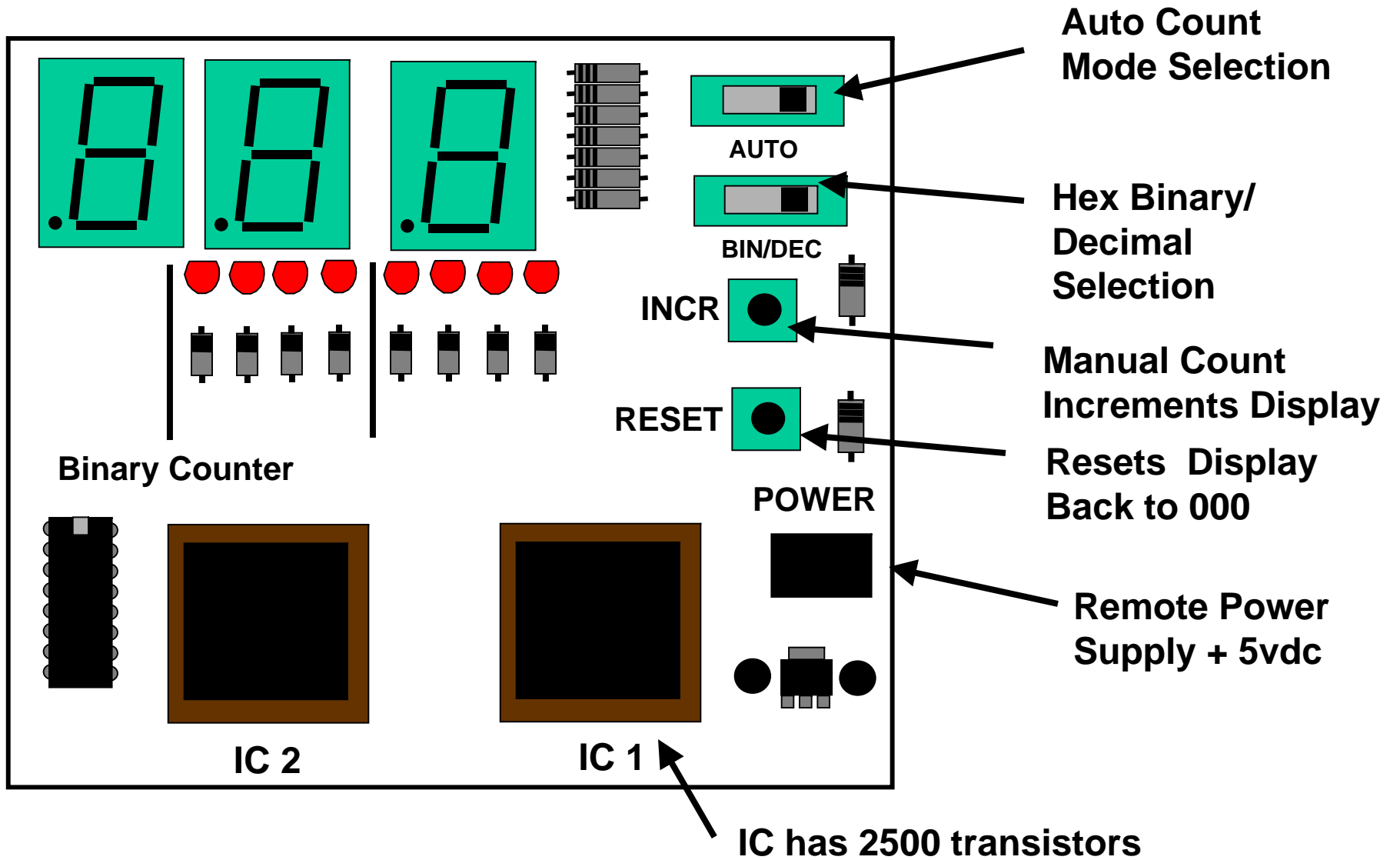

1m
18m

Do not pass out yet

Binary Tool Kit Design

IC consisting of 2500 Transistors

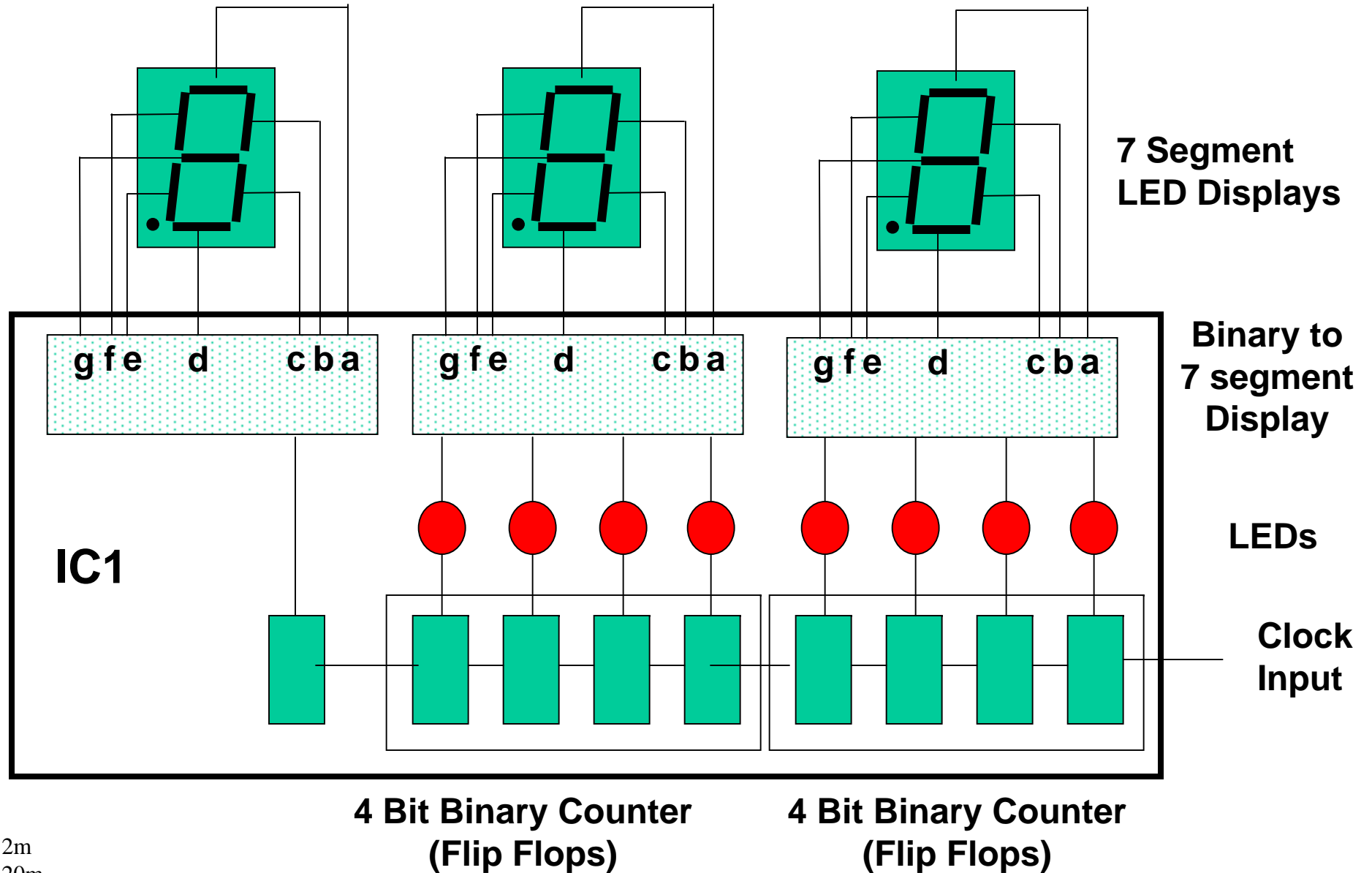

Binary Tool Kit

Use Tool to find Answers

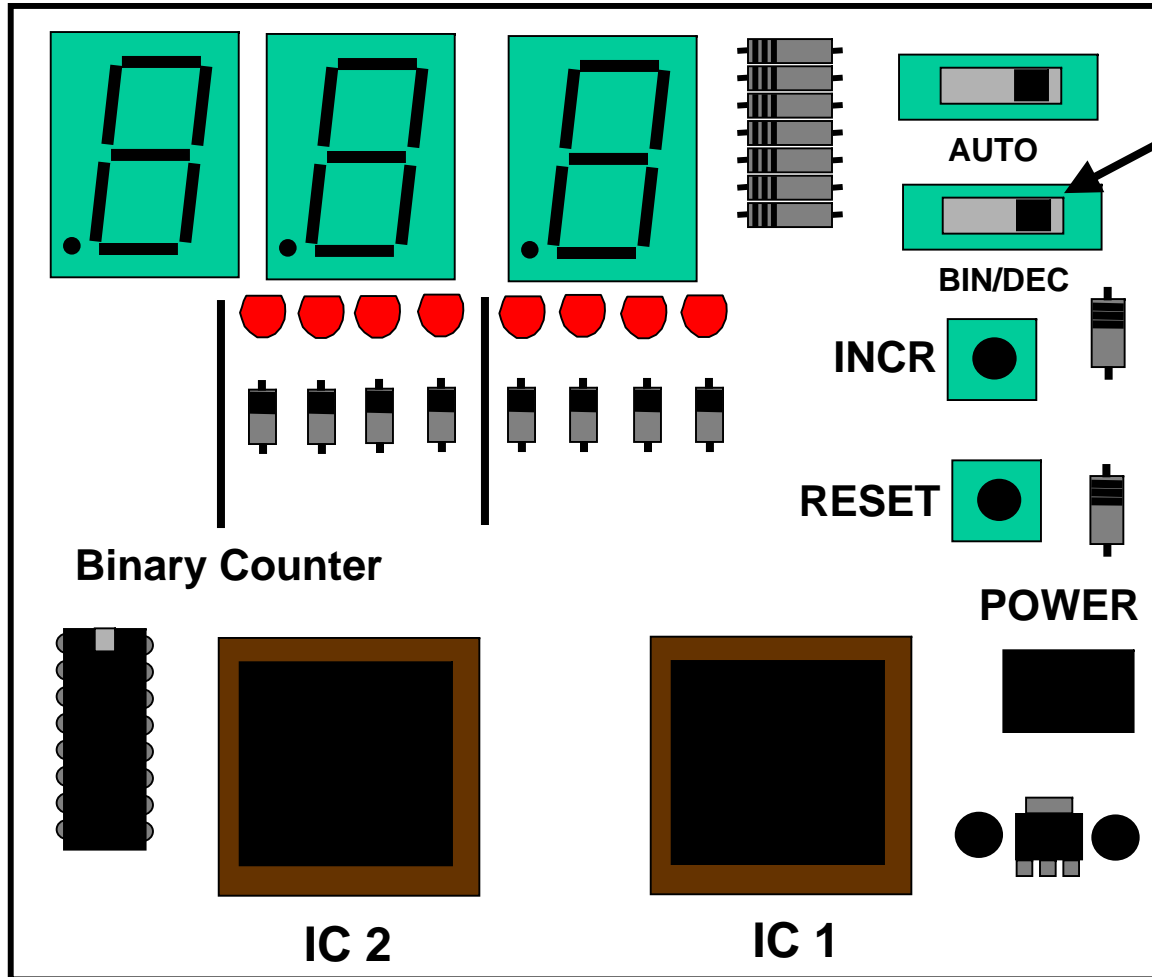

Decimal Count

- 0000 = 0 0
- 0001 = 0 1
- 0010 = ____
- 0011 = ____
- 0100 = ____
- 0101 = 0 5
- 0110 = 0 6
- 0111 = 0 7
- 1000 = 0 8
- 1001 = ____
- 1010 = ____
- 1011 = ____
- 1100 = ____
- 1101 = 1 3
- 1110 = 1 4
- 1111 = 1 5

Micro-Processor Controlled Counter Project

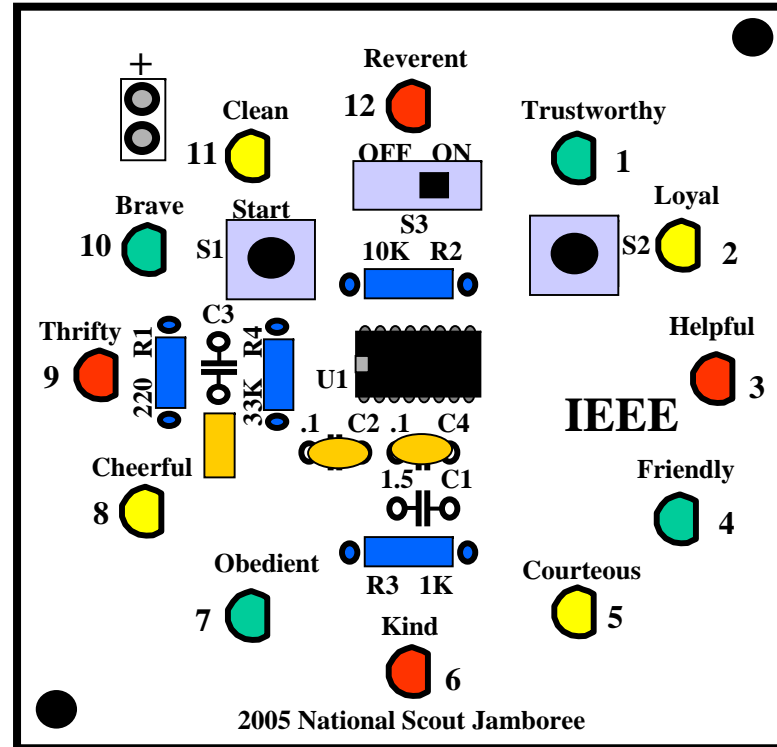

**Kit contains a microprocessor that is programmed to drive 12 LEDs
The micro is programmed to starts blinking lights fast, then slowly
comes to a stop. You will draw the circuit schematic this class, then
next class build the kit.**

Micro-Processor Controlled Counter

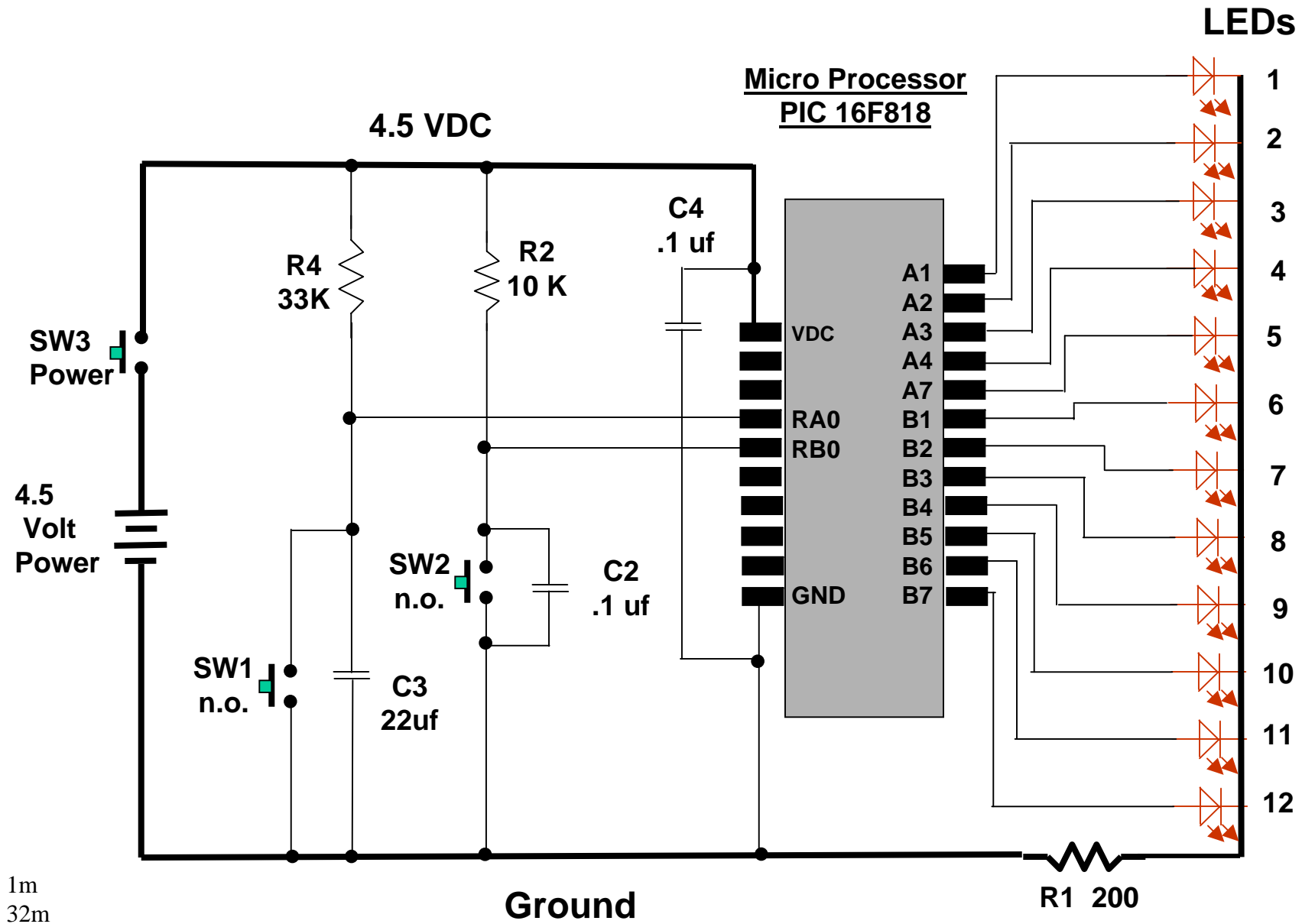

1m
32m

Micro-Processor Controlled Counter

After SW3 is closed, voltage flows to the circuit.
 The micro is programmed to count in binary from 1 to 12
 When SW1 is pressed, capacitor C3 is discharged.
 Then when the button is released the capacitor
 begins to charge from "0" to 4.5 volts. As
 the voltage goes up, the LED's start
 incrementing at a fast rate and as the
 voltage approaches 4.5 slows down
 and stops.
 By pressing SW2, changes the
 mode so the LED's blink
 randomly.

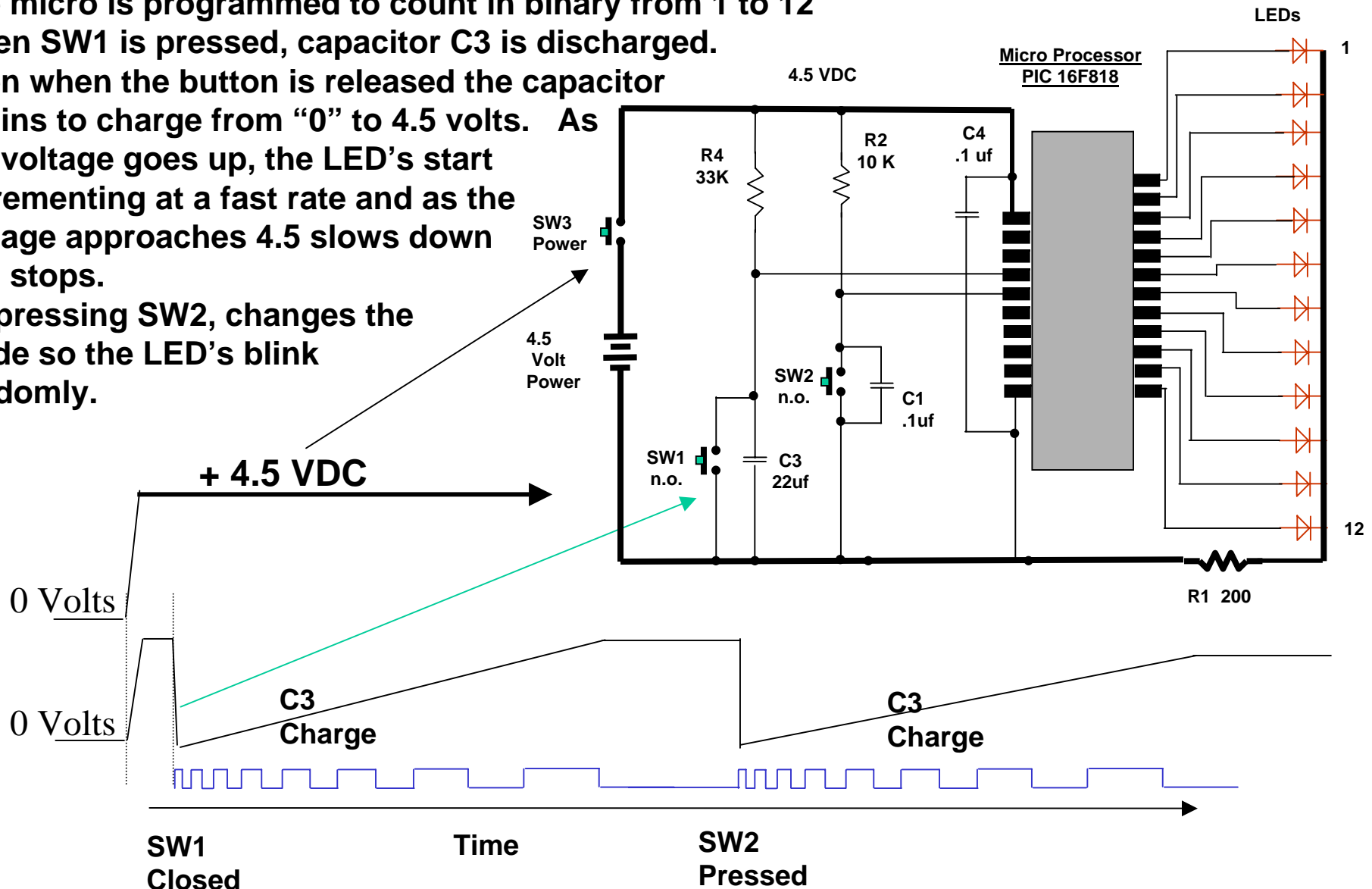

3m
35m

Micro-Processor Controlled Counter Circuit

Draw the Schematic / Connect the lines

